**READ ME !** 

Thank you for purchasing a Front Runner Suzuki Jimny (2018 - Current) Ladder.

Before you start, take a moment to familiarize yourself with the Fitting Instructions and the included components.

Refer to Page 2 for a list of all the components, quantities and tools required.

**IMPORTANT WARNING!** 

IT IS CRITICAL THAT ALL FRONT RUNNER PRODUCTS BE PROPERLY AND SECURELY ASSEMBLED AND ATTACHED TO YOUR VEHICLE. IMPROPER ATTACHMENT COULD RESULT IN AN AUTOMOBILE ACCIDENT, AND COULD CAUSE SERIOUS BODILY INJURY OR DEATH. YOU ARE RESPONSIBLE FOR ASSEMBLING AND SECURING ALL FRONT RUNNER PRODUCTS TO YOUR VEHICLE, CHECKING THE ATTACHMENTS PRIOR TO USE, AND PERIODICALLY INSPECTING THE PRODUCTS FOR ADJUSTMENT, WEAR AND DAMAGE. THEREFORE, YOU MUST READ AND UNDERSTAND ALL OF THE INSTRUCTIONS AND PRECAUTIONS SUPPLIED WITH YOUR FRONT RUNNER PRODUCT PRIOR TO INSTALLATION OR USE. IF YOU DO NOT UNDERSTAND ALL OF THE INSTRUCTIONS AND CAUTIONS, OR IF YOU HAVE NO MECHANICAL EXPERIENCE AND ARE NOT THOROUGHLY FAMILIAR WITH THE INSTALLATION PROCEDURES, YOU SHOULD HAVE THE PRODUCT INSTALLED BY A PROFESSIONAL INSTALLER OR OTHER QUALIFIED PERSONNEL.

**NOTE:** Front Runner will not be responsible for any damage caused by the failure to install the product according to these instructions.

Please call us if you have any questions about the installation of this product.



# 1 GET ORGANIZED

## IN THE BOX

1	1 X	Ladder Rung Assembly
2	1 X	Bottom Mount Bracket
3	1 X	Top Step Plate
4	9 X	M6 x16 Flange Button Head
5	1 X	Spare Wheel Mounting Bracket
6	9 X	M6 Nyloc Nut
7	9 X	M6 Nut Cap
8	1 X	Ladder Hinge Mount Bracket
9	2 X	M8 x 35 Button Head Bolt
10	2 X	M8 x 16 x 1.6 Flat Washer
11	1 X	Buffer
12	1 X	M5 x 16 Button Head Bolt
13	1 X	M5 Nyloc Nut
14	1 X	M5 Nut Cap
15	1 X	Spacer
16	1 X	M10 Flat Washer
17	1 X	M10 x 40 x 1.25 Hex Bolt
18	1 X	Hinge Spacer
19	1 X	Rubber U Channel (76mm Long)

## TOOLS NEEDED

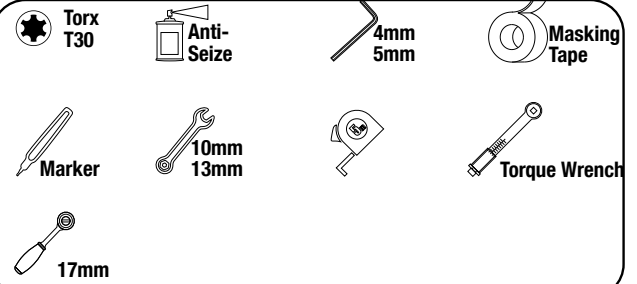
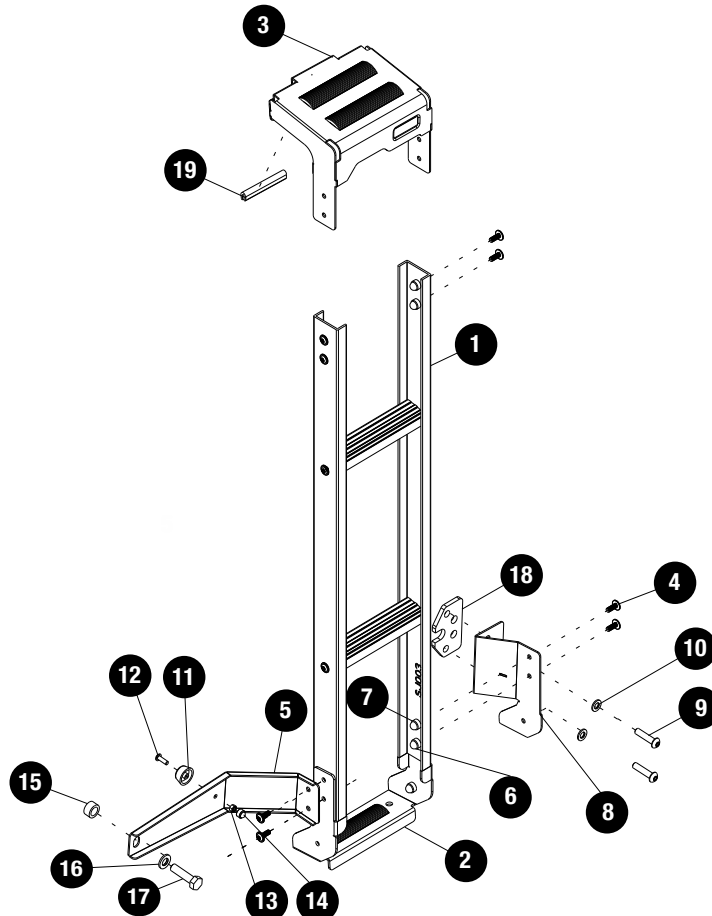

FIGURE 1.1



2

FIT AND SECURE

2.1

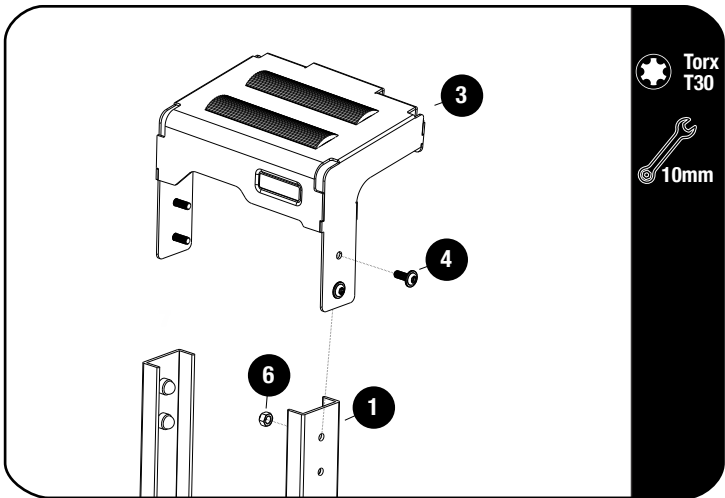

Loosely assemble the Ladder Rung Assembly (Item 1) to the Ladder Step Bracket (Item 3) using M6 x 16 Flange Button Head Bolts and M6 Nyloc Nuts (Items 4 & 6).



**NOTE:**  
Ladder Step Bracket (Item 3) to go Over Ladder Rung Assembly (Item 1)

2.2

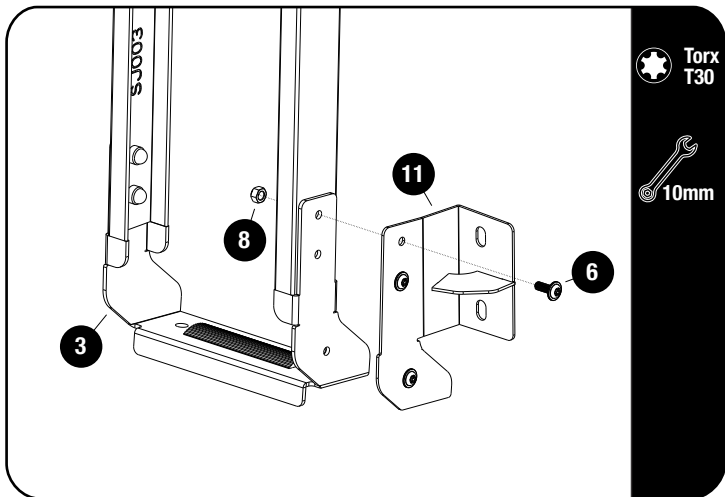

Loosely assemble the Bottom Mount Bracket and Ladder Hinge Bracket (Item 2 & 8) to the assembly in 2.1 using M6 x 16 Flange Button Head Bolts and M6 Nyloc Nuts (Items 4 & 6).

2.3

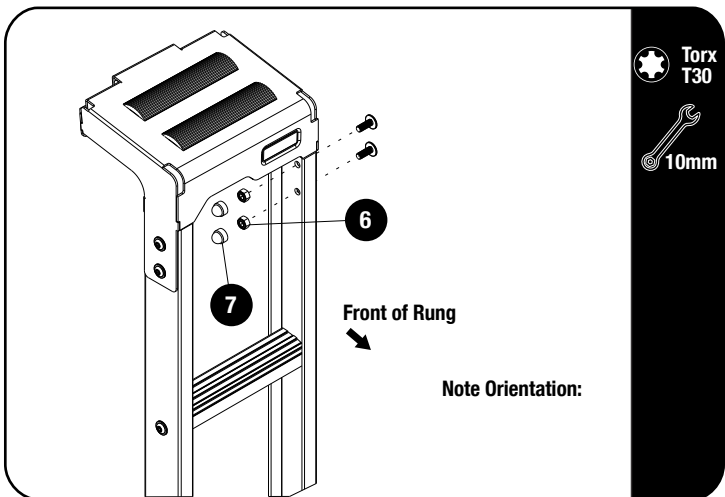

Fully tighten all Fasteners.  
Place M6 Nut Caps (Item 7) over all M6 Nyloc Nuts (Item 6).

Front of Rung  
Note Orientation:

2

**FIT AND SECURE**

2.4

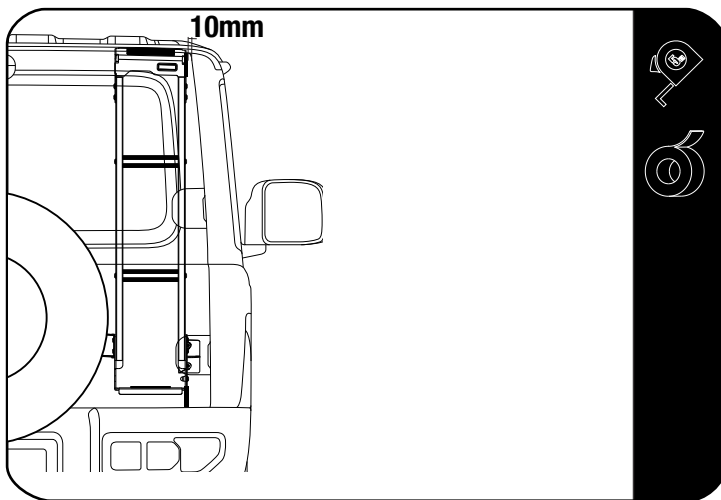

Place the U-Channel Rubber (Item 10) over the door edge where the Top Step Plate (Item 4) will be secured.

Measure 10mm from the right hand edge of the door and mark with masking tape as shown.

Hook the Ladder assembly from 2.3 over the door lining up the right hand side with the mark you made earlier.

2.5

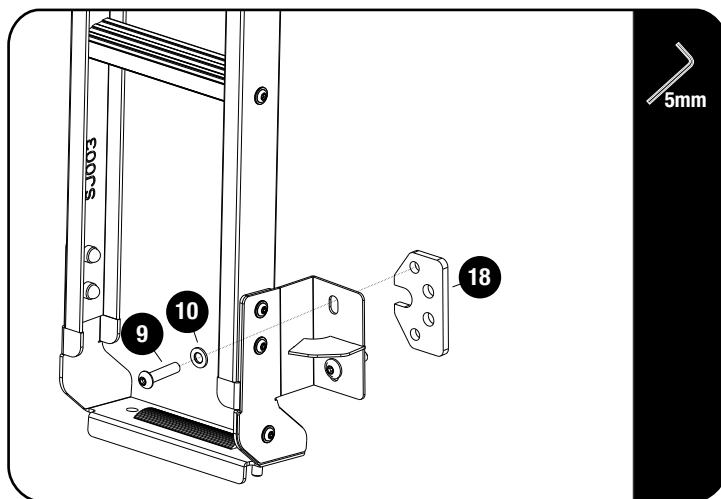

Unclip and remove the bottom hinge cover.

Loosen and remove the two hinge screws.

Secure the Ladder Hinge Mount Bracket to the hinge using M8 x 35 Button Head Bolts, M8 x 16 x 1.6 Flat Washers and the Hinge Spacer (Items 9, 10 & 18)



**Tightening Torque:**

M8 : 15-20Nm / 11.06 ft lb - 14.75 ft lb

2.6

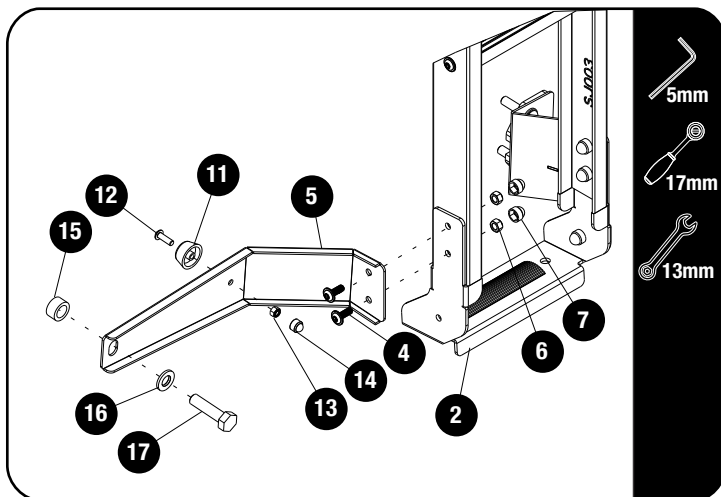

Assemble the Spare Wheel Mounting Bracket (Item 5), by attaching the Buffer (Item 11) with the M5 x 16 Button Head Bolt, M5 Nyloc Nut and M5 Nut Cap. (Items 12,13 and 14).

Unscrew the OEM Bottom Right Bolt on the OEM Spare Wheel Mounting Bracket. Place the Spare Wheel Mounting Bracket (Arm) (Item 5) over the hole on the OEM Spare Wheel Mounting Bracket with the Spacer (Item 15) inbetween. Secure with the M10 Flat Washer and M10 x 40 x 1.25 Hex Bolt. (Items 16 & 17)

Attach the Spare Wheel Mounting Bracket to the Bottom Mount Bracket (Item 2) with M6 x 16 Flange Button Head Bolts, M6 Nyloc Nuts and tighten. Place M6 Nut Caps on all M6 Nyloc Nuts.



**Tightening Torque:**

M6 : 8-10Nm / 5.9 ft lb - 7.38 ft lb

**3**

### **FINISH**

Congratulations! You did it. Take a step back and admire your work!

**4**

### **INSTALL OTHER VEHICLE AND RACK ACCESSORIES**

Now's the time to visit your favorite Front Runner Dealer in person or online.

**Be sure to tag us. We love to see our gear in action! #FrontRunnerOutfitters #BornToRoam**

**Share your adventures on:** 