



Australia's #1 Suspension Specialists

# PEDDERS

## SUSPENSION



## Subaru Catalogue

Edition 2  
September 2016



Australia's #1 Suspension Specialists

# PEDDERS

## SUSPENSION

**Straight advice, specialists you understand and... No Bull**





# Pedders

Specialists since 1950

The Pedder's organisation began back in 1950 when owner, Roy Pedder, opened Pedder's Die-Cast Welding Service in Hawthorn Road, Carnegie and soon after, moved to Claremont Ave, Malvern. Roy, an ex-RAAF World War 2 plane welder, began the business by fixing general household items, but with his skills in welding die-cast materials, found his niche in the automotive market in smash repairs and shock absorbers.

With the weakness of the early lever type shocks in Australian conditions coupled with the demand for his services in this area, Roy decided to specialise in the repair and reconditioning of shock absorbers and subsequently the business grew rapidly. The workshop was moved to a factory in Wren Road, Moorabbin, while sales continued in Malvern. In the mid-50's Pedder's became renowned for reconditioning shock absorbers that the rest of the trade said were unrepairable. By the late 50's Pedder's had 15 people servicing more than 3000 shocks per month.

Pedder's moved with demand and its reconditioning work gained wide acceptance. In 1964 Pedder's were literally mass producing its own brand of shocks by simply modifying overseas designs to suit local needs. The Pedder's shocks featured altered internal valve rates based on specific market needs and these new shocks were marketed for the first time under the Pedder's banner. Soon the shocks took on the striking red colour for better identification and by the end of the 60's, Pedder's shock absorbers had grown in reputation and popularity.

In 1972, Roy's eldest son Ron, took over the company. In 1974, Ron took the next significant step and utilising what the company had learnt from reconditioning other's shocks began designing its own. To support this radical step, Ron Pedder saw the only way to ensure good distribution of his product was to open Pedder's own stores. This strategy paved the way for the commencement of aggressive franchising to support Pedder's own homegrown brand. This move made Pedder's unique worldwide in that it developed, manufactured, distributed and installed its own product through its own retail chain.

Today, Pedder's is headed up by Ron Pedders eldest son Mark who took on the role as Managing Director in early 2006. Pedders now has over 120 locations Australia wide, most of which are franchised.

Pedders has recently expanded its export markets to now includes shipments to distributors in **Poland (Ozparts European Warehouse)** and **UK (Warehouse Pedders Suspension)**, Korea, U.K., Europe, The Middle East, Thailand, Indonesia, Kenya, South Africa, Malaysia, China & U.S.A. Pedder's employs over 500 people Australia-wide and has suspension products for the majority of vehicles on our roads today. This large, multinational automotive company has come a long way from a backyard welding shops, and most if not all of this most if not all of this growth has been due to the determination, dedication and foresight of our most important asset – our people.



# OVERVIEW

## Ezi Fit

The heavy duty Pedders Ezi Fit Spring and Shock Absorber combination kits were designed, developed and manufactured to provide precise control without compromising ride comfort for your Subaru. Supplied as a complete assembly of matched suspension components. The Pedders Ezi Fit Spring and Pedders Shock Absorber combination kits are available in various formats to suit your needs.

## All New Design

The "All New" design Pedders Shock Absorbers found in the new Ezi Fit kits are an ideal alternative for the motorist who is simply looking to return the vehicle back to its original ride height and handling qualities. However, the additional features give similar performance to premium quality gas shock absorbers at a more affordable price. These features include; precisely tuned valving, heavy duty construction and accurate nitrogen gas pressurisation. These key features equate to a superior shock absorber with smoother and quieter ride characteristics. Pedders Coil Springs also included in the kits are produced under a strict manufacturing process, this ensures that Pedders Coil Springs exceed original equipment tolerances and are equal to or better than other manufacturers in the world for consistency, loaded ride height and reliability.

## Key Features:

- Supplied as a matched set of pre-assembled suspension components including Pedders Shock Absorber, Pedders Spring and Pedders Strut Mount.
- Reduced installation time as the components are supplied pre-assembled and ready for direct fitment.
- Individually shock dyno tested for quality assurance.
- The Pedders coil spring supplied in the Ezi Fit kit enables your Subaru to be used for load, carrying, 4wd, touring and towing applications depending on kit choice.
- Pedders Ezifit kits are also available for Forester models as a replacement to the factory Nivomat self-levelling suspension units - this enables the vehicle to be returned to its original ride height.
- Pedders Ezifit kits are also available in "SportsRyder" variant for those seeking to improve the looks and handling of their car.



## Springs

All Pedders coil springs are manufactured according to a strictly controlled design, manufacturing and testing process that ensures Pedders' coil springs exceed original tolerances and are equal to or exceed the best in the world in consistency of rate, loaded height and reliability. This provides for a quality product in every coil produced.

## Pedders TrakRyder coil springs offer the following key features and benefits:

- Premium quality grade steel
- Stress relieved and 100% QA inspected
- Load height tested
- Raised height for increased articulation
- Heavy duty units provide precise spring rates needed for ride control
- 2 Year / 25,000 mile / 40,000 km warranty

Whilst most manufacturers will quote an amount of lift or drop on their springs, this takes no account of what is actually fitted and how much they may have settled over time. To avoid disappointment or confusion, Pedders quote an "installed height". This is measured from the bottom of the wheel rim at the quoted wheel size as shown in the diagram. Comparing this to your car will show you just what the change in height will be.

### Pedders Ride Height Measurement Example

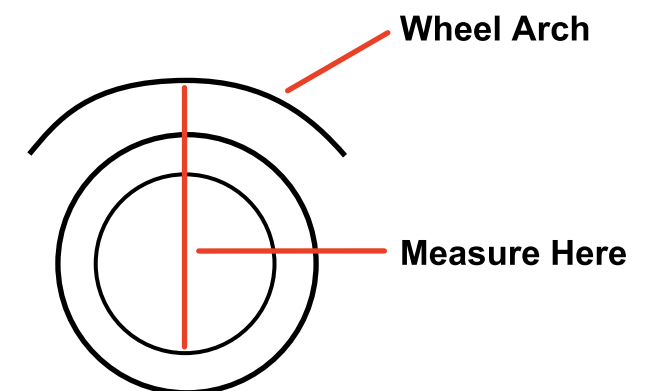

**NB: Add 12.5 mm for each inch larger than quoted wheel size  
 Decuct 12.5 mm for each inch smaller than quoted wheel size**



# OVERVIEW

## Shock Absorbers

Pedders Shock Absorbers are an ideal alternative for the motorist who is simply looking to return his/her vehicle back to its original ride and handling qualities. However, the additional features give similar performance to premium quality gas shock absorbers at a more affordable price. These features include; precisely tuned valving, heavy duty construction and accurate nitrogen gas pressurisation. These key features equate to a superior shock absorber with smoother and quieter ride characteristics.

## SportsRyder Shock Absorbers

For motorists who are after that extra level of performance and sports handling Pedders Suspension has a product range called SportsRyder. The gas-charged GSR SportsRyder shock range uses tailored nitrogen gas pressure to enable precise control without compromising on ride comfort. Gas SportsRyder sealed struts and cartridges are high performance, heavy duty replacement units which deliver a new standard of comfort and road holding ability for today's hi-tech, lighter vehicles. At the pinnacle of the SportsRyder range comes the eXtreme XA, a world class, height adjustable coil over unit featuring 30 position adjustable bump and rebound damping setting at the click of a button.



## Suspension Bushes:

Suspension bushings are the link between your vehicle and its springs, struts and shock absorbers. Suspension bushings provide the movement and/ or mounting points in your vehicle's suspension system. Therefore, these suspension components can influence ride quality, steering feel, as well as the grip of the tyres, performance of the brakes and stability of the shock absorbers. Should these suspension components be worn, an unpredictable and more to the point unsafe motor vehicle can be the result.

Pedders polyurethane bushing are designed to allow flexibility of movement of the entire suspension, while maintaining correct mounting and alignment of individual parts. Pedders polyurethane bushes boast superior design and chemistry characteristics to ensure necessary durability, performance and comfort as its required.

## Benefits include:

- Improved road holding, steering feel and braking
- Less change in suspension geometry under load, braking and through corners
- Enhanced suspension life and less repair time
- Maintained alignment for longer tyre life.





# SUBARU FORESTER

## FRONT

Model	Year	Pedders Shock	Sports Ryder Shock	Standard Spring	Lowering Spring	Raising Spring	Hardware
<b>Forester SF</b> Identifiable from Chassis code letters „SF”	1997 - 2002	8997L 8997R <b>EziFit Strut Kits</b> 1 x 808997L 1 x 808997R <b>STD Ride Height</b> 1 x 809997L 1 x 809997R <b>LOWER Ride Height</b>	N/A	2 x 7346	2 x 7240	N/A	Struts Mounts 2 x 580092  Camber Pins 1 x 458014
Notes:		Pedders Shock can be used as a direct replacement for standard. Also suitable or use with Pedders springs including lowering springs.		Ride height 660mm with 16" wheels	Ride height 610mm with 16" wheels		
<b>Forester SG</b> Identifiable from Chassis code letters "SG"	2002 - 2008	1 x 8472L 1 x 8472R <b>EziFit Struts</b> 1 x 808472L 1x 808472R <b>STD Ride Height</b> 1 x 809472L 1 x 809472R <b>LOWER Ride Height</b>	N/A	2 x 230132	2 x 7240	N/A	Strut Mounts 2 x 580092  Camber Pins 1 x 458014
Notes:		Pedders Shock can be used as a direct replacement for standard. Also suitable for use with Pedders springs including lowering springs.		Ride height 660mm with 16" wheels.	Ride height 610mm with 16" wheels. Lowers vehicle approx 60mm so bump travel is limited.		

## REAR

Pedders Shock	Sports Ryder Shock	Standard Spring	Lowering Spring	Raising Spring	Hardware	EziFit Kit	eXtreme Xa Coilover Kit
1 x 8998L 1 x 8998R <b>EziFit Struts</b> 1 x 808998L 1 x 808998R <b>STD Ride Height</b> 1 x 809998L 1 x 809998R <b>LOWER Ride Height</b> 1 x 800998L 1 x 800998R <b>HD / Raised Ride Height</b>	N/A	2 x 7455	2 x 7246	2 x 7755	Bumpstop & Boot Kit 2 x 4532  Camber Pins 1 x 458014	<b>Lowering Kit</b> 803032	160061
Pedders Shock. If used to replace Subaru Self Levelling shocks, then springs, part number 7455 or 7755 MUST be used. See note about self levelling		Ride Height 660mm with 16" wheels. See note about self levelling.	Ride Height 625mm with 16" wheels. See note about self levelling.	Ride Height 685mm with 16" wheels. Ideal for towing and load carrying. See note about self levelling.		Ride Height 610mm front 625mm rear with 16" wheels.	Coilover kit featuring height and 30 position damping adjustment.
1 x 8473L 1 x 8473R <b>EziFit Struts</b> 1 x 808473L 1 x 808473R <b>STD Ride Height</b> 1 x 809473L 1 x 809473R <b>LOWER Ride Height</b> 1 x 800473L 1 x 800473R <b>HD / Raised Ride Height</b>	N/A	2 x 7233	2 x 7237	2 x 240131	Strut Mounts 2 x 580091  Camber Pins 1 x 458014	<b>Lowering Kit</b> 803033  <b>Lowering Kit SportsRyder</b> 803046	160053
		Ride height 655mm with 16" wheels.	Ride height 605mm with 16" wheels.	Ride height 675mm 16" wheels.		<b>Lowering Kit</b> Ride Height 610mm front 625mm rear  <b>SportsRyder Kit</b> 610mm front 625mm rear	Coilover kit featuring height and 30 position damping adjustment.

## COMPLETE VEHICLE

# SUBARU FORESTER

## FRONT

Model	Year	Pedders Shock	Sports Ryder Shock	Standard Spring	Lowering Spring	Raising Spring	Hardware
<b>Forester SH</b> Identifiable from Chassis code letters "SH"	2008 - 2013	1 x 129038L 1 x 129038R <b>EziFit Struts</b> 1 x 808038L 1 x 808038R <b>STD Ride Height</b> 1 x 809038L 1 x 809038R <b>LOWER Ride Height</b>	N/A	2 x 230022	2 x 220022	N/A	Strut Mounts 2 x 580092  Camber Pins 1 x 458014
Notes:		Pedders Shock can be used as a direct replacement for standard. Also suitable or use with Pedders springs including lowering springs.		Ride height same as standard.	Ride height 625mm with 16" wheels.		
<b>Forester SJ</b> Identifiable from Chassis code letters "SJ"	2013 - on	1 x 129038L 1 x 129038R <b>EziFit Struts</b> 1 x 808038L 1 x 808038R <b>STD Ride Height</b> 1 x 809038L 1 x 809038R <b>LOWER Ride Height</b>	N/A	2 x 230022	2 x 220022	N/A	Strut Mounts 2 x 580092  Camber Pins 1 x 458014
Notes:		Pedders Shock can be used as a direct replacement for standard. Also suitable or use with Pedders springs including lowering springs.		Ride height same as standard	Ride height 625mm with 16" wheels		
Notes about Subaru self levelling suspension.	All UK specification Foresters and many imports were fitted with self levelling suspension from new. These are failure prone. When replacing these with conventional shocks; it is <b>ESSENTIAL</b> that matching springs are used. <b>DO NOT</b> re-use the original spring with a conventional replacement damper. Ride height <b>WILL</b> be too low and improper performance will result.						

## REAR

## COMPLETE VEHICLE

Pedders Shock	Sports Ryder Shock	Standard Spring	Lowering Spring	Raising Spring	Hardware	EziFit Kit	eXtreme Xa Coilover Kit
2 x 122329 <b>EziFit Struts</b> 2 x 802329 <b>STD Ride Height</b> 2 x 809329 <b>LOWER Ride Height</b> 2 x 800329 <b>HD / Raised Ride Height</b>	N/A	2 x 230023	2 x 220023	2 x 240023	Strut Mounts 2 x 580091	<b>Lowering Kit</b> 803034	160062
Pedders Shock. If used to replace Subaru Self Levelling shocks, then springs, part number 230023 or 220023 <b>MUST</b> be used. See note about self levelling		Ride Height 665mm with 16" wheels. See note about self levelling.	Ride Height 615mm with 16" wheels. See note about self levelling.	Ride Height 685mm with 16" wheels. See note about self levelling.		Ride Height 625mm front. 615mm rear with 16" wheels.	Coilover kit featuring height and 30 position damping adjustment.
2 x 122329 <b>EziFit Struts</b> 2 x 802329 <b>STD Ride Height</b> 2 x 809329 <b>LOWER Ride Height</b> 2 x 800329 <b>HD / Raised Ride Height</b>	N/A	2 x 230023	2 x 220023	2 x 240023	Strut Mounts 2 x 580091	<b>Lowering Kit</b> 803034	160062
Pedders Shock. If used to replace Subaru Self Levelling shocks, then springs, part number 230023 or 220023 <b>MUST</b> be used. See note about self levelling		Ride Height 665mm with 16" wheels. See note about self levelling.	Ride Height 615mm with 16" wheels. See note about self levelling.			Ride Height 625mm front 615mm rear	Coilover kit featuring height and 30 position damping adjustment.
Notes about Subaru self levelling suspension.	All UK specification Foresters and many imports were fitted with self levelling suspension from new. These are failure prone. When replacing these with conventional shocks; it is <b>ESSENTIAL</b> that matching springs are used. <b>DO NOT</b> re-use the original spring with a conventional replacement damper. Ride height <b>WILL</b> be too low and improper performance will result.						



# SUBARU IMPREZA

## FRONT

Model	Year	Pedders Shock	Sports Ryder Shock	Standard Spring	Lowering Spring	Raising Spring	Hardware
<b>Impreza 'Classic' 'GC' and 'GF'</b> models. Identifiable from Chassis coded letter 'GC' or 'GF'	1992 - 2000	1 x 8837L 1 x 8837R	1 x 9837L 1 x 9837R <b>EziFit Struts</b> 1 x 909837L 1 x 909837R <b>LOWER Ride Height</b>	N/A	2 x 2389	N/A	Bump Stop & Boot 2 x 4352  Strut Mounts 2 x 580092  Camber Pins 1 x 458014
Notes: Not including 2wd models		Pedders shock can be used as a direct replacement for standard. Also suitable for use with Pedders springs including lowering springs	Pedders Sports Ryder shock. Ideal for those seeking an improvement in handling. Also suitable for use with Pedders lowering springs		Ride height 565mm with 16" wheels		
<b>Impreza WRX 'Classic' 'GC' and 'GF'</b> models. Identifiable from Chassis coded letter 'GC' or 'GF'.	1992 - 2000	N/A	1 x 9837L 1 x 9837R <b>EziFit Struts</b> 1 x 909837L 1 x 909837R <b>LOWER Ride Height</b>	2 x 2346	2 x 2389		Bump Stop & Boot 2 x 4352  Strut Mounts 2 x 580092  Camber Pins 1 x 458014
Notes: Not including 2wd models			Pedders Sports Ryder shock. Good replacement for standard WRX shocks. Also suitable for use with Pedders lowering springs.	Ride height 585mm with 16" wheels.	Ride height 565mm with 16" wheels		

## REAR

## COMPLETE VEHICLE

Pedders Shock	Sports Ryder Shock	Standard Spring	Lowering Spring	Raising Spring	Hardware	EziFit Kit	eXtreme Xa Coilover Kit
1 x 8861L 1 x 8861R	1 x 9861L 1 x 9861R <b>EziFit Struts</b> 1 x 909861L 1 x 909861R <b>LOWER Ride Height</b>	N/A	2 x 2390 <b>SEDAN only</b>	N/A	Bump Stop & Boot 2 x 4354  Strut Mounts 2 x 580015  Camber Pins 1 x 458014	<b>Lowering Kit</b> 803036  <b>SEDAN only</b>	160020
Pedders shock can be used as a direct replacement for standard. Also suitable for use with Pedders springs including lowering springs	Pedders Sports Ryder shock. Ideal for those seeking an improvement in handling. Also suitable for use with Pedders lowering springs		Ride height 565mm with 16" wheels			Ride height 565mm front 565mm rear with 16" wheels	Coilover kit featuring height and 30 position damping adjustment
N/A	1 x 9861L 1 x 9861R <b>EziFit Struts</b> 1 x 909861L 1 x 909861R <b>LOWER Ride Height</b>	2 x 2346	2 x 2390 <b>SEDAN only</b>	N/A	Bump Stop & Boot 2 x 4354  Strut Mounts 2 x 580015  Camber Pins 1 x 458014	<b>Lowering Kit</b> 803036  <b>SEDAN only</b>	160020
	Pedders Sports Ryder shock. Good replacement for standard WRX shocks. Also suitable for use with Pedders lowering springs	Ride height 580mm with 16" wheels	Ride height 560mm with 16" wheels			Ride height 565mm front 565mm rear with 16" wheels	Coilover kit featuring height and 30 position damping adjustment

# SUBARU IMPREZA

## FRONT

Model	Year	Pedders Shock	Sports Ryder Shock	Standard Spring	Lowering Spring	Raising Spring	Hardware
<b>Impreza 'Bug Eye' 'GD' and 'GG'</b> models Identifiable from Chassis code letter 'GD' or 'GG'	2000 - 2002	1 x 8980L 1 x 8980R	1 x 9980L 1 x 9980R <b>Ezifit Struts</b> 1x 909980L 1 x 909980R <b>LOWER Ride Height</b>	N/A	2 x 2389	N/A	Bump Stop & Boot 2 x 4352  Strut Mounts 2 x 580092  Camber Pins 1 x 458014
Notes:		Pedders shock can be used as a direct replacement for standard. Also suitable for use with Pedders springs including lowering springs	Pedders Sports Ryder shock. Ideal for those seeking an improvement in handling. Also suitable for use with Pedders lowering springs		Ride Height 585mm with 17" wheels		
<b>Impreza WRX 'Bug Eye' 'GD' and 'GG'</b> models. Identifiable from Chassis code letter 'GD' or 'GG'	2000 - 2002	1 x 8980L 1 x 8980R	1 x 9980L 1 x 9980R <b>Ezifit Struts</b> 1x 909980L 1 x 909980R <b>LOWER Ride Height</b>	N/A	2 x 2389	N/A	Strut Mount 2 x 580092  Bump Stop & Boot 2 x 4359
Notes:		Pedders shock can be used as a direct replacement for standard. Also suitable for use with Pedders springs including lowering springs	Pedders Sports Ryder shock. Ideal for those seeking an improvement in handling. Also suitable for use with Pedders lowering springs		Ride Height 585mm with 17" wheels		

## REAR

Pedders Shock	Sports Ryder Shock	Standard Spring	Lowering Spring	Raising Spring	Hardware	EziFit Kit	eXtreme Xa Coilover Kit
1 x 8981L 1 x 8981R	1 x 9981L 1 x 9981R <b>Ezi Fit Struts</b> 1 x 909981L 1 x 909981R <b>LOWER Ride Height</b>	N/A	2 x 222397 <b>SEDAN only</b>  2 x 222397-1 <b>WAGON only</b>	N/A	Bump Stop & Boot 2 x 4354  Camber Pins 1 x 458014	<b>Lowering Kit</b> 803035 <b>SEDAN only</b> <b>Lowering Kit</b> 803047 <b>WAGON only</b>	160021
Pedders shock. Can be used as a direct replacement for standard. Also suitable for use with Pedders springs including lowering springs	Pedders Sports Ryder shock. Ideal for those seeking an improvement in handling. Also suitable for use with Pedders lowering springs		Ride Height 590mm with 17" wheels			Ride Height 585mm front 590mm rear with 17" wheels <b>both SEDAN and WAGON</b>	Coilover kit featuring height and 30 position
1 x 8981L 1 x 8981R	1 x 9981L 1 x 9981R <b>Ezi Fit Struts</b> 1 x 909981L 1 x 909981R <b>LOWER Ride Height</b>	N/A	2 x 222397 <b>SEDAN only</b>  2 x 222397-1 <b>WAGON only</b>	N/A	Bump Stop & Boot 2 x 4354  Boot Only 2 x 4366  Camber Pins 1 x 458014	<b>Lowering Kit</b> 803035 <b>SEDAN only</b> <b>Lowering Kit</b> 803047 <b>WAGON only</b>	160021
Pedders shock. Can be used as a direct replacement for standard. Also suitable for use with Pedders springs including lowering springs	Pedders Sports Ryder shock. Ideal for those seeking an improvement in handling. Also suitable for use with Pedders lowering springs		Ride Height 590mm with 17" wheels			Ride height 585mm front 590mm rear with 17" wheels <b>both SEDAN and WAGON</b>	Coilover kit featuring height and 30 position damping adjustment

## COMPLETE VEHICLE



# SUBARU IMPREZA

## FRONT

Model	Year	Pedders Shock	Sports Ryder Shock	Standard Spring	Lowering Spring	Raising Spring	Hardware
<b>Impreza 'Blob Eye' 'GD' and 'GG' models.</b> Identifiable from Chassis code letter 'GD' or 'GG'	2002 - 2007	1 x 8980L 1 x 8980R	1 x 9980L 1 x 9980R <b>Ezifit Struts</b> 1 x 909980L 1 x 909980R <b>LOWER Ride Height</b>	N/A	2 x 2389	N/A	Strut Mount 2 x 580092  Bump Stop & Boot 2 x 4359  Camber Pins 1 x 458014
Notes:		Pedders shock can be used as a direct replacement for standard. Also suitable for use with Pedders springs including lowering springs	Pedders Sports Ryder shock. Ideal for those seeking an improvement in handling. Also suitable for use with Pedders lowering springs		Ride Height 585mm with 17" wheels		
<b>Impreza WRX &amp; Sti ONLY</b> <b>5x100 PCD. NOT WIDE TRACK</b>  <b>'Blob Eye' 'GD' and 'GG' models.</b> Identifiable from Chassis code letter 'GD' or 'GG'	2002-2004*	1 x 8980L 1 x 8980R	1 x 9980L 1 x 9980R <b>Ezifit Struts</b> 1x 909980L 1 x 909980R <b>LOWER Ride Height</b>	N/A	2 x 2389	N/A	Strut Mount 2 x 580092  Bump Stop & Boot 2 x 4359  Camber Pins 1x 458014
Notes:	*Up to approx April 2004. See notes at back of catalogue for explanation	Pedders shock can be used as a direct replacement for standard. Also suitable for use with Pedders springs including lowering springs	Pedders Sports Ryder shock. Ideal for those seeking an improvement in handling. Also suitable for use with Pedders lowering springs		Ride Height 585mm with 17" wheels		

## REAR

## COMPLETE VEHICLE

Pedders Shock	Sports Ryder Shock	Standard Spring	Lowering Spring	Raising Spring	Hardware	EziFit Kit	eXtreme Xa Coilover Kit
1 x 8425L 1 x 8425R	1 x 9981L 1 x 9981R <b>Ezi Fit Struts</b> 1 x 909981L 1 x 909981R <b>LOWER Ride Height</b>	N/A	2 x 2399 <b>SEDAN only</b>	N/A	Strut Mount 2 x 580091  Bump Stop & Boot 2 x 4354 Boot Only 2 x 4366  Camber Pins 1 x 458014	<b>Lowering Kit</b> 803035 <b>SEDAN only</b> <b>Lowering Kit</b> 803047 <b>WAGON only</b>	160021
Pedders shock can be used as a direct replacement for standard. Also suitable for use with Pedders springs including lowering springs	Pedders Sports Ryder shock. Ideal for those seeking an improvement in handling. Also suitable for use with Pedders lowering springs					Ride height 585mm front 590mm rear with 17" wheels	Coilover kit featuring height and 30 position damping adjustment
8425L 8425R	1 x 9981L 1 x 9981R <b>Ezi Fit Struts</b> 1 x 909981L 1 x 909981R <b>LOWER Ride Height</b>	N/A	2 x 2399 <b>SEDAN only</b>	N/A	Bump Stop & Boot 2 x 4354  Boot Only 2 x 4366  Camber Pins 1 x 458014	<b>Lowering Kit</b> 803035 <b>SEDAN only</b> <b>Lowering Kit</b> 803047 <b>WAGON only</b>	160021
Pedders shock. Can be used as a direct replacement for standard. Also suitable for use with Pedders springs including lowering springs	Pedders Sports Ryder shock. Ideal for those seeking an improvement in handling. Also suitable for use with Pedders lowering springs					Ride height 585mm front 590mm rear with 17" wheels <b>both SEDAN and WAGON</b>	Coilover kit featuring height and 30 position damping adjustment

# SUBARU IMPREZA

## FRONT

Model	Year	Pedders Shock	Sports Ryder Shock	Standard Spring	Lowering Spring	Raising Spring	Hardware
<b>Impreza 'Bug Eye' and 'Hawk Eye' 'GD' and 'GG' models.</b> Identifiable from Chassis code letter 'GD' or 'GG'	2004 - 2007	1 x 8980L 1 x 8980R or 1 x 129055L 1 x 129055R <b>See notes.</b>	1 x 9980L 1 x 9980R <b>Ezifit Struts</b> 1 x 909980L 1 x 909980R <b>LOWER Ride Height</b>	N/A	2 x 2389	N/A	Boot 2 x 4359  Camber Pins 1 x 458014
Notes:	NOTE: UK spec WRX models from July 2005 on have later style hub to shock mounting. These require shock part numbers 129055L & 129055R	Pedders shock can be used as a direct replacement for standard. Also suitable for use with Pedders springs including lowering springs. MUST use 4359 bumpstop and boot when fitting these.			Ride Height 585mm with 17" wheels		
<b>Impreza WRX STi 'Bug Eye' and 'Hawk Eye' 'GD' and 'GG' models.</b> Identifiable from Chassis code letter 'GD' or 'GG'  <b>WIDE TRACK MODELS</b> <b>5x114 PCD ONLY</b>	2002 - 2007	N/A	N/A	N/A	2 x 2946	N/A	Strut Mount 2 x 580092  Camber Pins 1 x 458014
Notes:					Lowers by approx 20mm		

## REAR

## COMPLETE VEHICLE

Pedders Shock	Sports Ryder Shock	Standard Spring	Lowering Spring	Raising Spring	Hardware	EziFit Kit	eXtreme Xa Coilover Kit
8425L 8425R	1 x 9981L 1 x 9981R <b>Ezi Fit Struts</b> 1 x 909981L 1 x 909981R <b>LOWER Ride Height</b>	N/A	2 x 2399	N/A	Bump Stop & Boot 2 x 4354  Camber Pins 1 x 458014	<b>Lowering Kit</b> 803035  <b>Lowering Kit</b> 803047 <b>WAGON only</b>	160021
Pedders shock. Can be used as a direct replacement for standard. Also suitable for use with Pedders springs including lowering springs	Pedders Sports Ryder shock. Ideal for those seeking an improvement in handling. Also suitable for use with Pedders lowering springs MUST use 5052 to fit this model. See notes at back of catalogue.					Ride height 585mm front 590mm rear with 17" wheels <b>both SEDAN and WAGON</b>	Coilover kit featuring height and 30 position damping adjustment
N/A	N/A	N/A	2 x 2947	N/A	Camber Pins 1 x 458014	<b>Lowering Kit</b> 803049	160023
			Lowers by approx 20mm				Coilover kit featuring height and damping adjustment. Suits Sti models with 30mm clevis bracket only



# SUBARU IMPREZA

## FRONT

Model	Year	Pedders Shock	Sports Ryder Shock	Standard Spring	Lowering Spring	Raising Spring	Hardware
<b>Impreza 'Shark Eye' 'GE' and 'GH' models.</b> Identifiable by Chassis letter 'GE' or 'GH'	2007 - 2011	1 x 129055L 1 x 129055R	N/A	N/A	2 x 2986	N/A	Strut Mount 2 x 585013  Bump Stop 2 x 4350  Camber Pins 1 x 458014
Notes:		Pedders shock can be used as a direct replacement for standard. Also suitable for use with Pedders springs including lowering springs			Ride height 580mm with 17" wheels		
<b>Impreza WRX 'Shark Eye' 'GE' and 'GH' models.</b> Identifiable by Chassis letter 'GE' or 'GH'	2007 - 2011	N/A	N/A	N/A	2 x 2986	N/A	Camber Pins 1 x 458014
Notes:					Ride height 580mm with 17" wheels		

## REAR

## COMPLETE VEHICLE

Pedders Shock	Sports Ryder Shock	Standard Spring	Lowering Spring	Raising Spring	Hardware	EziFit Kit	eXtreme Xa Coilover Kit
2 x 122335	N/A	N/A	2 x 2987	N/A	Bump Stop 2 x 4360	N/A	160024
Pedders shock. Can be used as a direct replacement for standard. Also suitable for use with Pedders springs including lowering springs			Ride height 585mm with 17" wheels				Coilover kit featuring height and 30 position damping adjustment
N/A	N/A	N/A	2 x 2987	N/A			160024
			Ride height 585mm with 17" wheels				Coilover kit featuring height and damping adjustment. Suits Sti models with 30mm clevis bracket only

# SUBARU IMPREZA

## FRONT

Model	Year	Pedders Shock	Sports Ryder Shock	Standard Spring	Lowering Spring	Raising Spring	Hardware
<b>Impreza STi 'Shark Eye' 'GE' and 'GH' models.</b> Identifiable by Chassis letter 'GE' or 'GH'	2007 - 2011	N/A	N/A	N/A	2 x 2986	N/A	Camber Pins 1 x 458014
Notes:					Ride height 580mm with 17" wheels		
<b>Impreza WRX 'GV' models.</b> Identifiable from Chassis code letter 'GV'	2011 - 2013	1 x 129055L 1 x 129055R	N/A	N/A	2 x 220085	N/A	Strut Mounts 2 x 585013  Bump Stop 2 x 4350  Camber Pins 1 x 458014
Notes:					Lowers by approx 20mm		

## REAR

## COMPLETE VEHICLE

Pedders Shock	Sports Ryder Shock	Standard Spring	Lowering Spring	Raising Spring	Hardware	EziFit Kit	eXtreme Xa Coilover Kit
N/A	N/A	N/A	2 x 2987	N/A	N/A	N/A	160024
			Ride height 585mm with 17" wheels				Coilover kit featuring height and damping adjustment. Suits Sti models with 30mm clevis bracket only.
N/A	N/A	N/A	2 x 220086	N/A	Bump Stop Kit 2 x 4360	N/A	160024
			Lowers by approx 20mm				Coilover kit featuring height and damping adjustment. Suits Sti models with 30mm clevis bracket only

# SUBARU OUTBACK

## FRONT

Model	Year	Pedders Shock	Sports Ryder Shock	Standard Spring	Lowering Spring	Rasing/HD Spring	Hardware
<b>Outback 'BG'</b> . Identifiable from Chassis code letter 'BG'	1996 - 1998	1 x 8891L 1 x 8891R	N/A	2 x 7103	2 x 2103	2 x 7860	N/A
Notes:		Pedders shock can be used as a direct replacement for standard. Also suitable for use with Pedders springs including lowering springs		Ride height 625mm with 15" wheels	Ride height 585mm with 15" wheels	Ride height 650mm with 15" wheels	
<b>Outback 'BH'</b> . Identifiable from Chassis code letter 'BH' 4 cylinder models	1999- 2003	1 x 129008L 1 x 129008R	N/A	2 x 7346	2 x 2346	N/A	N/A
Notes: 4 cylinder models		Pedders shock can be used as a direct replacement for standard. Also suitable for use with Pedders springs including lowering springs		Ride height 680mm with 16" wheels	Ride height 625mm with 16" wheels		

## REAR

Pedders Shock	Sports Ryder Shock	Standard Spring	Lowering Spring	Rasing/HD Spring	Hardware	EziFit Kit	eXtreme Xa Coilover Kit
1 x 8892L 1 x 8892R	N/A	2 x 7720	2 x 2661	2 x 7782	N/A	N/A	N/A
Pedders shock can be used as a direct replacement for standard. Also suitable for use with Pedders springs including lowering springs		Ride height 625mm with 15" wheels	Ride height 585mm with 15" wheels	Ride height 650mm with 15" wheels			
2 x 122310	N/A	2 x 7512 or 2 x 2938 See Notes below.	2 x 7657	N/A	N/A	N/A	N/A
Pedders shock can be used as a direct replacement for standard. Also suitable for use with Pedders springs including lowering springs		Ride height 655mm with 16" wheels. For vehicles WITHOUT self levelling use 7512. To convert AWAY from self levelling use 2938 with shock 122310. See notes about self levelling	Ride height 610mm with 16" wheels. ONLY for vehicles never fitted with self levelling. See notes about self levelling.				

## COMPLETE VEHICLE



# SUBARU OUTBACK

## FRONT

Model	Year	Pedders Shock	Sports Ryder Shock	Standard Spring	Lowering Spring	Rasing/HD Spring	Hardware
<b>Outback 'BH'</b> . Identifiable from Chassis code letter ' <b>BH</b> ' 6 cylinder models	1999 - 2003	1 x 129008L 1 x 129008R	N/A	2 x 7708	2 x 2346	N/A	N/A
Notes: 6 cylinder models		Pedders shock can be used as a direct replacement for standard. Also suitable for use with Pedders springs including lowering springs		Ride height 650mm with 16" wheels	Ride height 625mm with 16" wheels		
<b>Outback BP</b> . Identifiable from Chassis code letters ' <b>BP</b> '	2003 onwards	1 x 129009L 1 x 129009R	N/A	N/A	N/A	N/A	N/A
Notes:		Pedders shock can be used as a direct replacement for standard.					
<b>Notes about Subaru Self Levelling Suspension:</b>	Some Outbacks were fitted with self levelling rear suspension from new. These are prone to failure. When replacing these with conventional shocks, it is <b>ESSENTIAL</b> that matching springs are used. <b>DO NOT</b> re-use the original spring with a conventional replacement damper. Ride height <b>WILL</b> be too low and improper performabce will result.						

## REAR

## COMPLETE VEHICLE

Pedders Shock	Sports Ryder Shock	Standard Spring	Lowering Spring	Rasing/HD Spring	Hardware	EziFit Kit	eXtreme Xa Coilover Kit
2 x 122310	N/A	2 x 7512 or 2 x 2938 See Notes below.	2 x 7657	N/A	N/A	N/A	N/A
Pedders shock can be used as a direct replacement for standard. Also suitable for use with Pedders springs including lowering springs		Ride height 655mm with 16" wheels. For vehicles <b>WITHOUT</b> self levelling use 7512. To convert <b>AWAY</b> from self levelling use 2938 with shock 122310. See notes about self levelling	Ride height 610mm with 16" wheels. <b>ONLY</b> for vehicles never fitted with self levelling. See notes about self levelling.				
2 x 122311	N/A	2 x 7512 or 2 x 2938 See Notes below.	N/A	N/A	N/A	N/A	N/A
Pedders shock can be used as a direct replacement for standard. Also suitable for use with Pedders springs including lowering springs		Ride height 655mm with 16" wheels. For vehicles <b>WITHOUT</b> self levelling use 7512. To convert <b>AWAY</b> from self levelling use 2938 with shock 122311. See notes about self levelling					
<b>Notes about Subaru Self Levelling Suspension:</b>	Some Outbacks were fitted with self levelling rear suspension from new. These are prone to failure. When replacing these with conventional shocks, it is <b>ESSENTIAL</b> that matching springs are used. <b>DO NOT</b> re-use the original spring with a conventional replacement damper. Ride height <b>WILL</b> be too low and improper performabce will result.						

# SUBARU BRZ / TOYOTA GT86

## FRONT

Model	Year	Pedders Shock	Sports Ryder Shock	Standard Spring	Lowering Spring	Hardware
<b>BRZ</b>	2012 onwards	N/A	1 x 149148L 1 x 149148R	N/A	2 x 220087	Camber Pins 1 x 458016
Notes:					Ride height 585mm with 17" wheels	

## REAR

## COMPLETE VEHICLE

Pedders Shock	Sports Ryder Shock	Standard Spring	Lowering Spring	Hardware	EziFit Kit	eXtreme Xa Coilover Kit
N/A	2 x 144354	N/A	2 x 220088	N/A	<b>Lowering Kit SportsRyder</b> 803048	160083 or 164083
			Ride height 585mm with 17" wheels.			Coilover kit featuring height and damping adjustment. With remote canisters.

## SUBARU IMPREZA WRX SHOCK HEIGHT GUIDANCE NOTE

During the course of production Subaru did, on occasion, alter the height of the car by means of altering the spring platforms that are welded to the shock body, rather than altering the spring itself.

Whilst being a perfectly valid way of altering vehicle height, it can cause some confusion when installing aftermarket springs as the expected height or drop may not be as expected. Likewise, the same issue can occur when fitting replacement shocks, as, if the springs seat height on the new shock is different from the old one, a change in vehicle height will take place.

All Pedders shocks utilise the more common higher spring seat position. If you want to be 100% sure of the outcome of fitting either Pedders shocks or springs, below is a diagram of the shocks and there dimensions.

Typically, some Subaru and some aftermarket shocks will be approx 10mm lower on this dimension. Where this is the case expect a lower ride height than that quoted.

Pedders advise an installed height rather than a "drop" which removes any possibility of doubt about the outcome of fitting lowering springs. Often springs are quoted as being 30mm lower for example. However this assumes that the springs you are replacing are as original. Often they have already been changed, or have settled significantly over time, meaning the 'drop' may not be as much as expected.

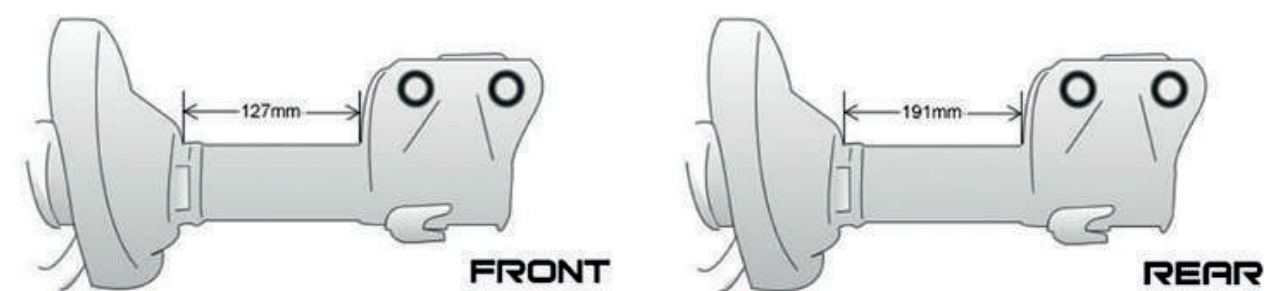

**PEDDERS SHOCK SPRING SEAT HEIGHTS**

## SUBARU IMPREZA FRONT SHOCK TO HUB MOUNTING DIFFERENCES NOTE

Pedders Suspension offer a range of Shocks for Subaru Impreza. However, selecting the correct one is not always as easy as you might expect due to the overwhelming number of changes made by Subaru during the production life of the vehicle.

The main issue to note however, is the change that took place in approx July 2005 spec WRX models. These changed to an inverted monotube damper but with a modified lower mounting where it bolts to the hub casting. This also affects early STi models with 5x100 Ped wheel stud pattern.

Owing to a change locating hole position, fitting the regular early style shocks will result in a positive camber situation on the front wheels at standard height.

This is far from desirable and will result in handling and driveability deficiencies.

When fitted with lowering coils acceptable camber settings can be achieved. If you wish to check which is fitted prior to purchase, please see the diagram below which enables you to identify which shock is suitable for your car.

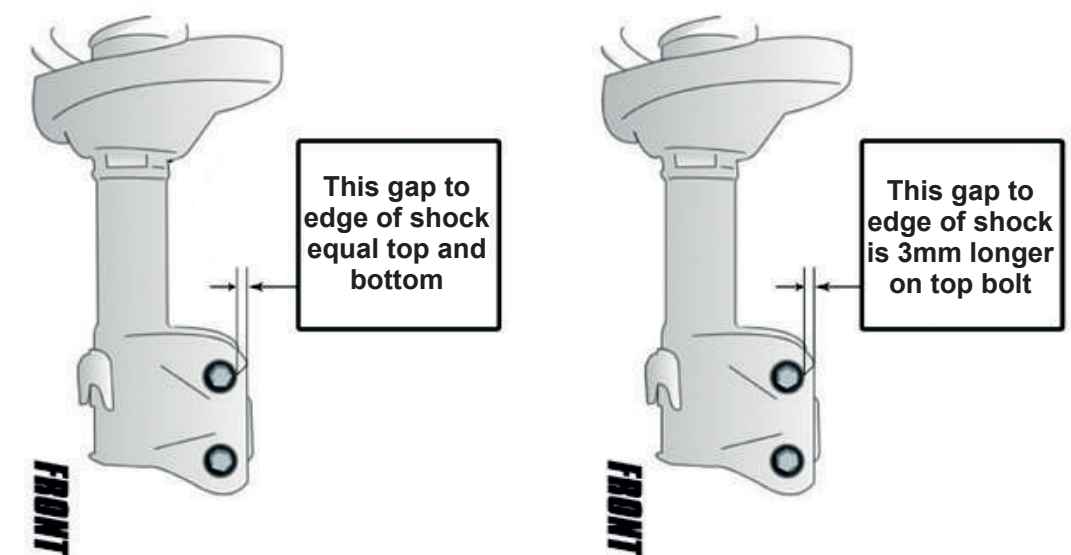

If as diagram above Pedders Shocks, part numbers as below will fit:

8980L  
 8980R  
 9980L  
 9980R

If as diagram above it will be necessary to use an oldest top mount or 458014 in the lower hole



## Springs



7240



230022



7346



7233



2389



2397



7708



2399



7657

## Shock Absorber



129007L/R



8997R/L



8472L



8472R



9981L/R



8452L/R



8980L/R



129008R/L

## Ezi Fit



808473L



808473R



909980R/L



909981R/L



## Ezi Fit Kits



Subaru Forester SF  
Ezi Fit Rear  
Conversion Kit



Subaru Forester SF  
Ezi Fit Rear Conversion Kit,  
Heavy Duty



Subaru Forester SF  
Ezi Fit Front  
Conversion Kit



Subaru Forester SF  
Ezi Fit Lowering Kit



Subaru Forester SG  
Ezi Fit Rear  
Conversion kit



Subaru Forester SG  
Ezi Fit Rear Conversion Kit,  
Heavy Duty



Subaru Forester SG  
Ezi Fit Front  
Conversion Kit



Subaru Forester SG  
Ezi Fit Lowering Kit



Subaru Forester SG  
Ezi Fit Rear  
Conversion kit



Subaru Forester  
SH & SJ Ezi Fit  
Rear Conversion Kit



Subaru Forester  
SH & SJ Ezi Fit  
Rear Conversion Kit  
Heavy Duty



Subaru Forester SH & SJ  
Ezi Fit Front Kit



Subaru Forester SH & SJ  
Ezi Fit Lowering Kit



Subaru Impreza GD  
Ezi Fit SportsRyder  
Lowering Kit

## Extreme Xa Kits



Subaru Impreza GC  
Extreme Xa Kit



Subaru Impreza GD  
Extreme Xa Kit



Subaru Impreza GD  
Extreme Xa Kit  
(STi wide track models only)



Subaru Impreza GE  
Extreme Xa Kit



Subaru Impreza GE & GV  
Extreme Xa Kit  
(Sti wide track models only)



Subaru Impreza GE  
Extreme Xa Kit



Subaru Forester SG  
Extreme Xa Kit



Subary Forester SH and SJ  
Extreme Xa Kit





PEDDERS PRODUCTS AVAILABLE & DISTRIBUTED BY:

## PEDDERS in EUROPE

Unit 12 Sterling Business Park  
Top Angel  
Buckingham Industrial Estate  
Buckinghamshire  
United Kingdom  
Mk18 1TH  
Tel: +44 1296 711044  
E-mail: [info@pedders.co.uk](mailto:info@pedders.co.uk)

46-48 Mazowiecka Str.  
87-100 Toruń  
Poland  
Mobile: +48 512 113 461  
+48 510 380 085  
E-mail: [info@pedders-ce.eu](mailto:info@pedders-ce.eu)



*Straight advice, specialists you understand and... No  Bull*